

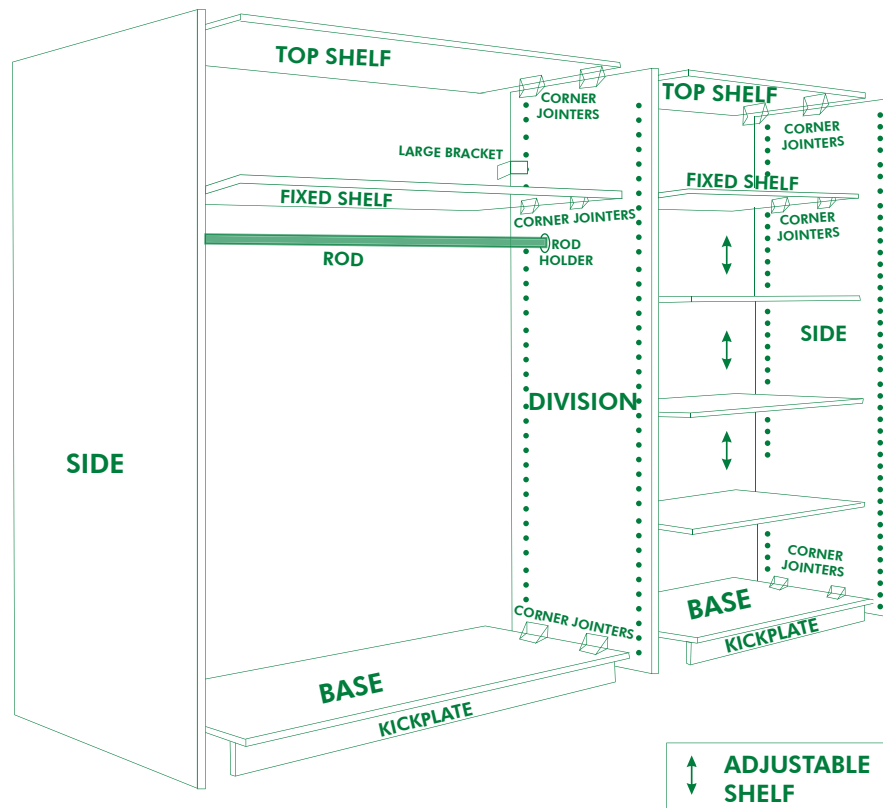

Manufacturers of high quality kitchen units and D.I.Y cupboards

DIY - Melamine Built-in- cupboards



Notes on Assembly

The unit you are about to assemble will be a bit rickety until it is fastened with the LARGE BRACKETS to the wall against which it is to stand.

Should you be assembling a one or two door cupboard the combination of SIDE/ BASE/ SIDE is constructed. (Using only one BASE)

Where a unit consists of more than two (2) doors the combination of SIDE/ BASE/ DIVISION/ BASE/SIDE is constructed. (Therefore using more than one BASE)

SIDES will be recognised by the fact that the 5mm holes on both edges are drilled only on the inside, whereas on a DIVISION the 5mm holes on both the edges are drilled right through the panel

Once the SIDE(S) / DIVISION(S) are placed on the floor next or between the BASE(S) the TOP- and FIXED SHELVE(S) are fixed into a permanent position by using the CORNER JOINTERS supplied.

It is essential that a FIXED SHELF be fitted approximately +/- 450mm from the TOP SHELF of each section of your unit.

With the carcass assembled, the SIDES and DIVISIONS must now be fastened to the wall against which it is to stand using the LARGE BRACKETS supplied. The LARGE BRACKETS must be placed between the TOP- and FIXED SHELVE(S)

IT IS *VER Y ESSENTIAL* THAT THE BASE(S) BE PLACED ABSOLUTELY HORIZONTAL AND THE SIDE(S)/ DIVISION(S) VERTICALLY TO ENSURE DOOR FITMENT, A SPIRIT LEVEL WILL BE VERY USEFUL ENSURING THIS.

Once the carcass is secured and if applicable, the HANGING ROD(S) may be fitted at this stage using the ROD HOLDER(S) supplied and the ADJUSTABLE SHELVES fitted by placing the SHELVE PINS supplied in their selected positions.

The DOOR(S) supplied are next to be fitted.

It is suggested that the HINGES first be fitted into the pot-holes drilled into the DOOR(S).

Fit the mounting plates to the HINGES on the DOOR(S).

Now holding the bottom of the DOORS in line with the bottom of the base, fasten the MOUNTING PLATE into the nearest corresponding holes on the SIDE(S) or DIVISIONS(S).

Should the re-alignment of the DOOR be necessary, please follow the instructions on the reverse side.

DOOR ALIGNMENT

OVERLAY ADJUSTMENT:

Plus/minus 2mm by turning Screw A.

DEPTH ADJUSTMENT:

Slacken Fixing Screw B (1 Turn), set required depth, and re-tighten Screw B.

HEIGHT ADJUSTMENT:

With appropriate mounting plates. Slacken screws C (1 turn), set required height, retighten screws C.

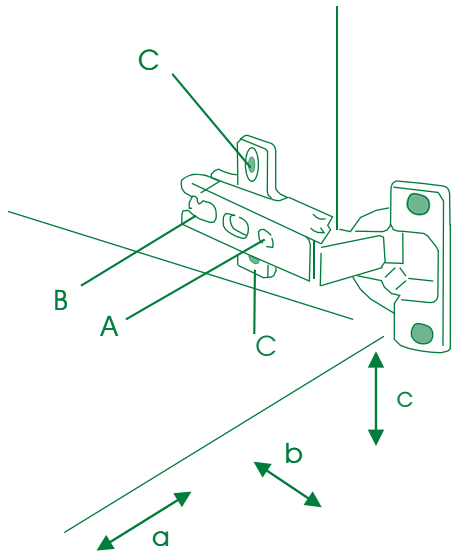

Manufacturers of high quality kitchen units and D.I.Y cupboards

PRETORIA FACTORY / SHOWROOM

132 Rietspruitstreet
Sunderland Ridge

Centurion

Tel: (012) 666 8555

Fax: (012) 666 8553

CORNER JOINTER

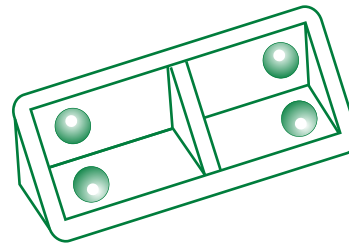

In fastening BASES, FIXED TOPS or SHELVES to a SIDE/ DIVISION, it must be borne in mind that the CORNER JOINTERS must not be placed immediately opposite one another on both sides of the DIVISION. It is recommended that they be placed about 5 to 10mm apart.

HANGING ROD HOLDER



SHELF PIN



LARGE BRACKET



WALL FASTENER
NOT SUPPLIED